

400 SERIES COMPRESSOR CROSS-SECTION

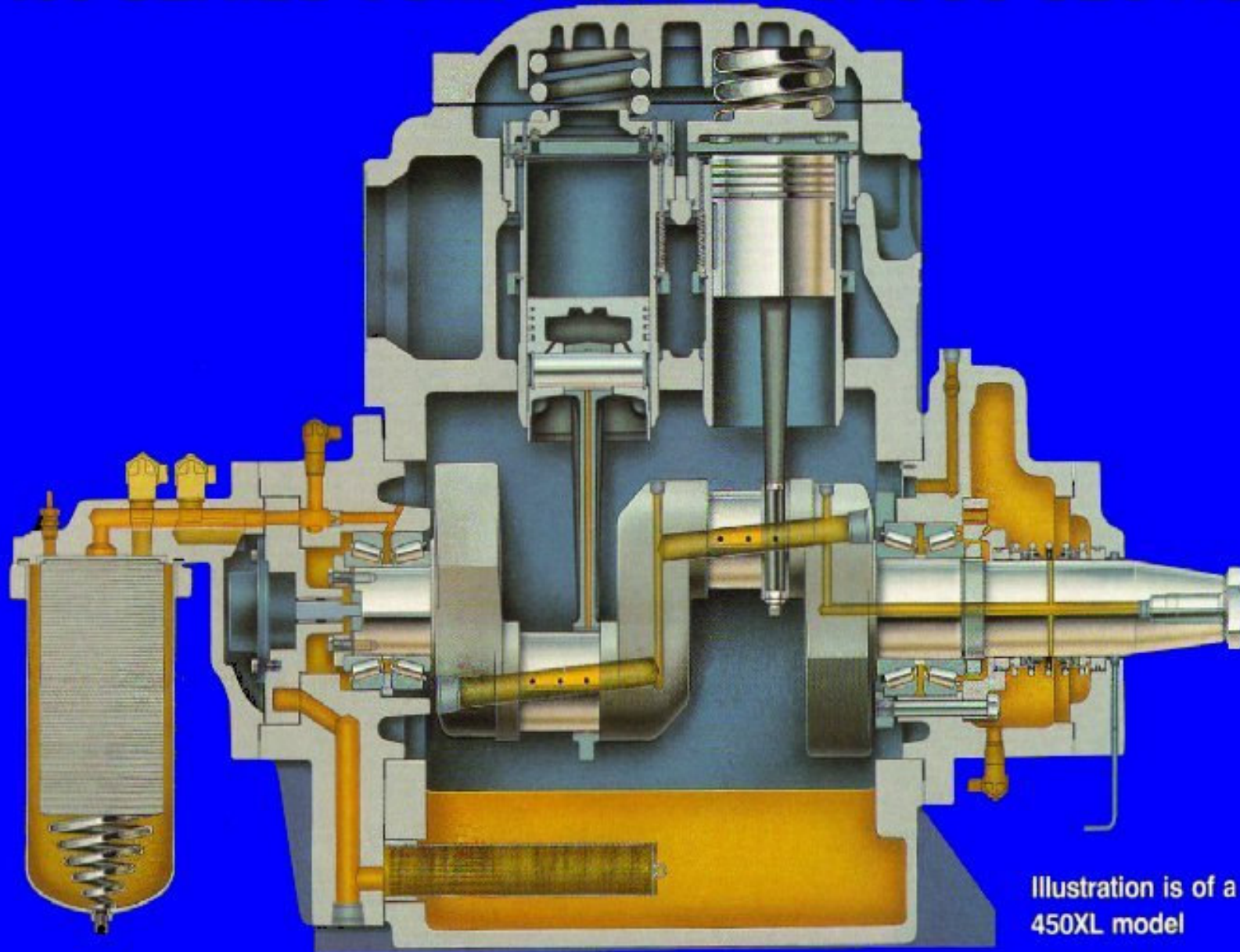
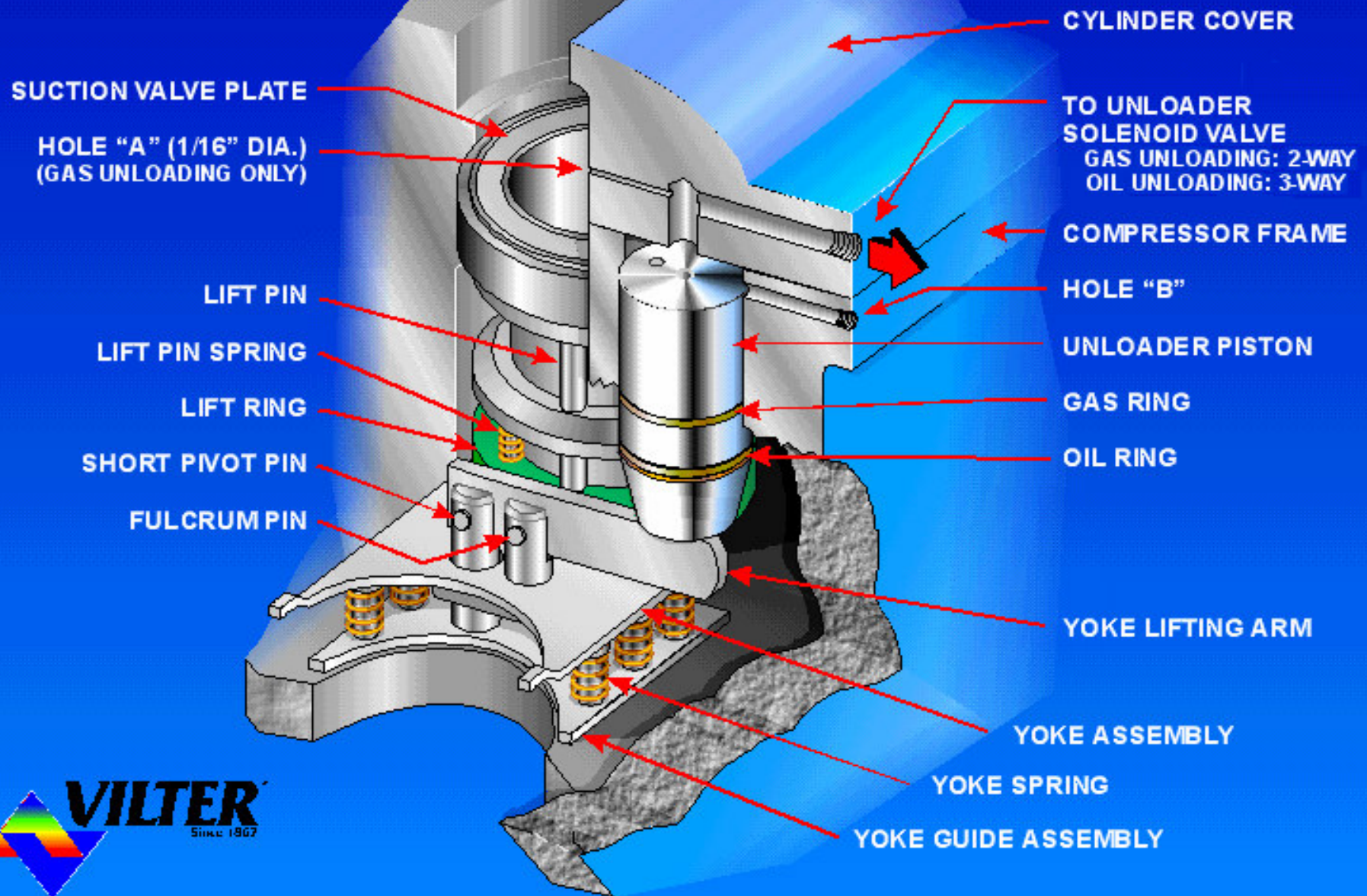
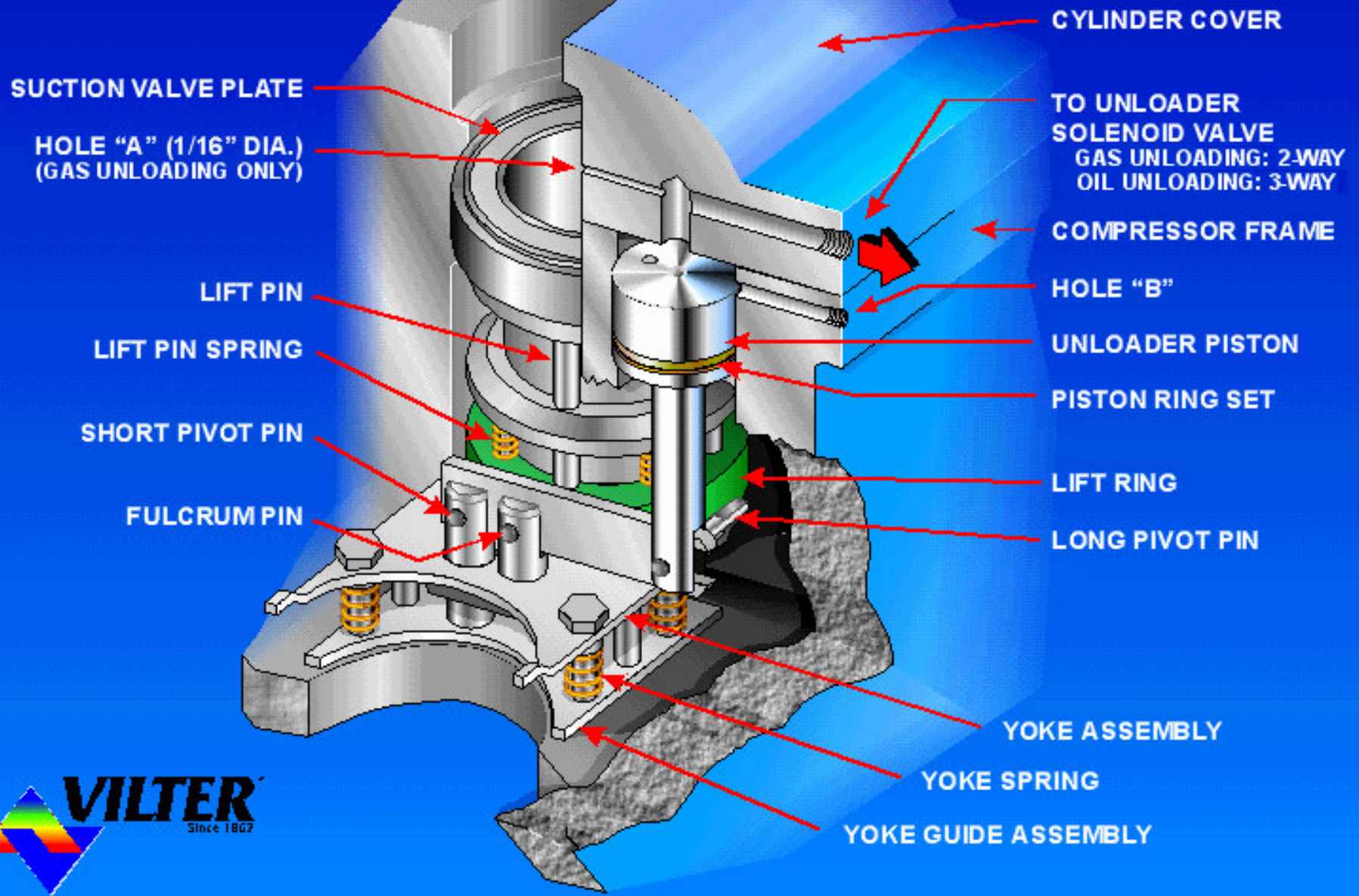

Illustration is of a 450XL model

NEW 400 SERIES CAPACITY REDUCTION MECHANISM



OLD 400 SERIES UNLOADER MECHANISM



CRANKSHAFT SEAL ASSEMBLY

